

# OHBA Safety Pages: Scaffolding Requirements

- Scaffold erection and dismantling must be done by, or supervised by, a qualified person or persons.
- The vertical supports of scaffolds must be – Placed on a firm base or mudsill – Capable of withstanding superimposed weight from the scaffold and anything placed on the scaffold.
- Do not use pallets, boxes, concrete blocks, bricks, or other unstable materials to support scaffolds.
- Base plates and mud sills: Poles, legs, posts, frames, and uprights must bear on base plates and mud sills or another firm foundation. Footings must offer full support without settling (e.g. dirt, sand, gravel, and warm asphalt are foundations that can allow settling or displacement).
  - A concrete slab is considered a firm foundation. However, it's still a good practice to use mud sills. Nailing base plates to mud sills will prevent a scaffold from “walking.”
  - The scaffold must be plumb and braced so that it does not sway. All scaffolds must be erected plumb and level and be designed for the intended use.
- Supported scaffolds with a height to base-width ratio greater than 4-to-1 (including outrigger supports) must be prevented from tipping. Use ties, guys, braces, or another means that provides at least the same degree of safety. Install guys, ties, or braces where the horizontal members support both the inner and outer legs. They must be installed according to the manufacturer's instructions (or at the closest horizontal member to the 4-to-1 height) and be repeated vertically at least every 20 feet if the scaffold is up to three feet wide, every 26 feet if the scaffold is more than three feet wide.
- Bracing requirements for prefabricated scaffolds must be installed according to the manufacturer's instructions. Bracing for job-built scaffolding must meet standards acceptable to Oregon OSHA.
- Load capacities: Is the load capacity for your scaffold rated for light, medium, or heavy duty? Is it rated for one person? Two? Three? Scaffolds and components must be able to support their own weight and at least four times the maximum intended load applied to them. The maximum intended load includes workers, equipment, and supplies.
- All scaffolds must be inspected before use by those who will use them, regardless of who erected them. No damaged or weakened scaffold may be used until it has been effectively repaired.

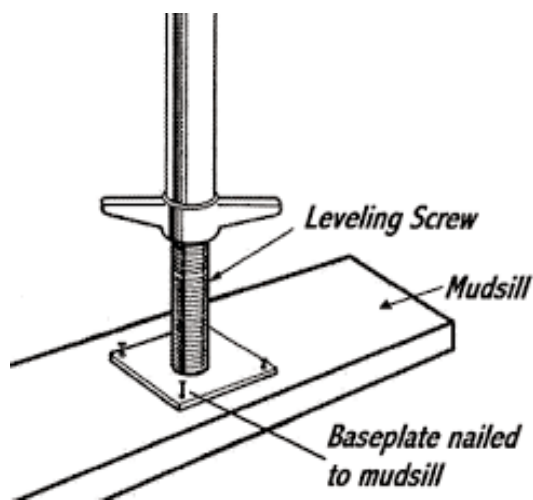

regulations or standards. The Members remain responsible for their own operations, safety practices and procedures and should consult with legal counsel as they deem appropriate.

The information we provide is not intended to include all possible safety measures and controls. In addition, the safety information we provide does not relieve the Members of its own duties and obligations with regard to safety concerns, nor does Oregon Home Builders Association guarantee to the Members or others that the Member's property, job sites and/or operations are safe, healthful, or in compliance with applicable laws,

Employer: \_\_\_\_\_ Project: \_\_\_\_\_

Date: \_\_\_\_\_ Time: \_\_\_\_\_ Shift: \_\_\_\_\_

Number in crew: \_\_\_\_\_ Number attending: \_\_\_\_\_

Safety or Health issues discussed. Include recent accident investigations and hazards involving tools, equipment, the work environment, work practices and any Safety or Health recommendations:

\_\_\_\_\_  
\_\_\_\_\_  
\_\_\_\_\_  
\_\_\_\_\_

Follow up on recommendations from last safety meeting:

\_\_\_\_\_  
\_\_\_\_\_

Record of those attending:

Name: (please print)	Signature:	Company:
1.		
2.		
3.		
4.		
5.		
6.		
7.		
8.		
9.		
10.		
11.		
12.		

Supervisor's remarks: \_\_\_\_\_

Supervisor: \_\_\_\_\_ (Print) \_\_\_\_\_ (Signature)